

# Mülltonnenbox

## Bin Box Set

### Inhalt

#### Content

Allgemeine Hinweise / General information	1
Benötigte Werkzeuge / Required tools	1
Bestandteile des Startersets / Starter set components	2
Bestandteile des Erweiterungssets / Extension set components	4
Zubehör / Accessories	6
Aufbauen der Box – Teil 1 / Assembling the box – part 1	8
Anbauen von Erweiterungssets / Attaching extension packs	10
Aufbauen der Box – Teil 2 / Assembling the box – part 2	12





### Allgemeine Hinweise

#### General information

- Bitte überprüfen Sie die Lieferung vor Beginn der Montage auf Vollständigkeit und einwandfreien Zustand. Bei Schäden, die während der Montage auftreten, können wir Ihnen keinen Garantieanspruch zugestehen. / Please check delivery before you start mounting. Everything has to be complete and in a faultless condition. We are not liable for damages resulting from mounting.
- Wir empfehlen die Montage mit zwei Personen durchzuführen. / Some of the assembly steps may require two people to complete.
- Achten Sie darauf, dass die Fläche, auf der Sie die Montage ausführen, die Oberflächen der Mülltonnenbox nicht zerkratzt. / Make sure that the surface on which you perform the assembly does not pose the risk of scratching the elements!
- Montieren Sie nicht bei Wind! Dieses Produkt muss im Boden verankert werden, um richtig gesichert zu sein! / Do not assemble in windy conditions! This product requires to be anchored into the ground in order to be properly secured!
- Halten Sie alle mitgelieferten Kleinteile oder Verpackungsmaterialien von kleinen Kindern fern. Bauteile haben scharfe Kanten oder ragen heraus, achten Sie beim Zusammenbau und im Gebrauch darauf. / Keep all supplied small parts or packaging materials away from small children. Components have sharp edges or protrude, pay attention to them during assembly and during daily use.
- Vergewissern Sie sich, dass Sie alle notwendigen Werkzeuge haben, bevor Sie mit der Montage beginnen! Achten Sie auf die Symbole, die anzeigen, welches Werkzeug Sie bei jedem Schritt verwenden müssen. / Make sure that you have all the necessary tools before you start the assembly! Look for symbols representing which tool to use in each step.

### Benötigte Werkzeuge

#### Required tools

 7 mm Schraubenschlüssel 7 mm spanner	 Kreuzschlitz Schraubendreher Phillips screwdriver
 10 mm Schraubenschlüssel 10 mm spanner	 Wasserwaage Level

# Bestandteile des Startersets

## Starter set components

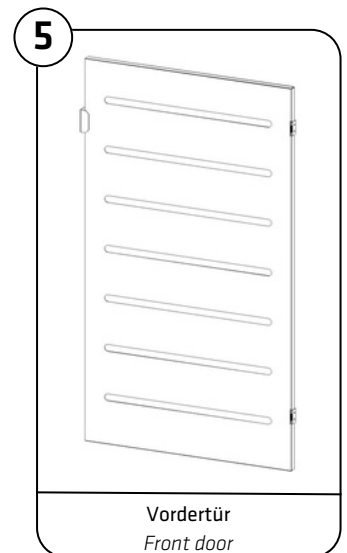
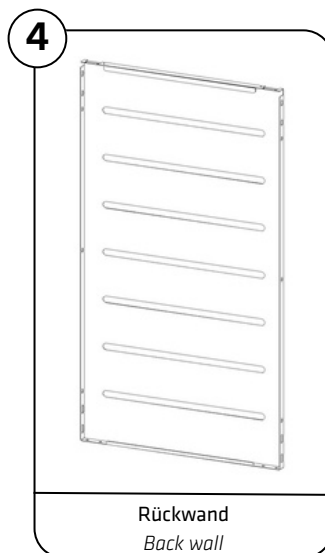
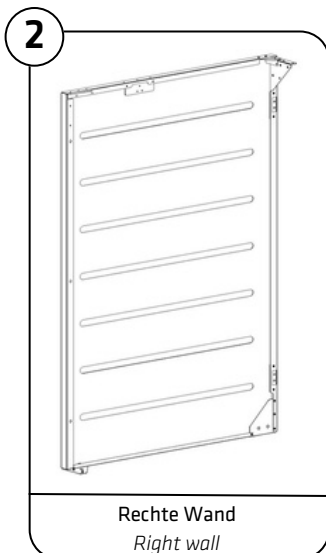
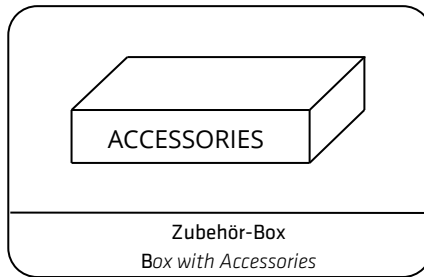
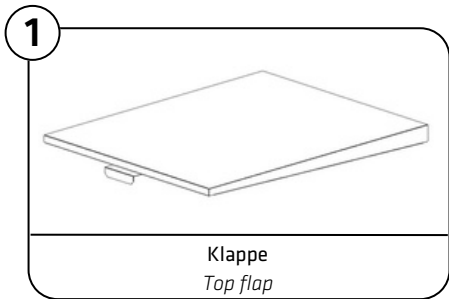
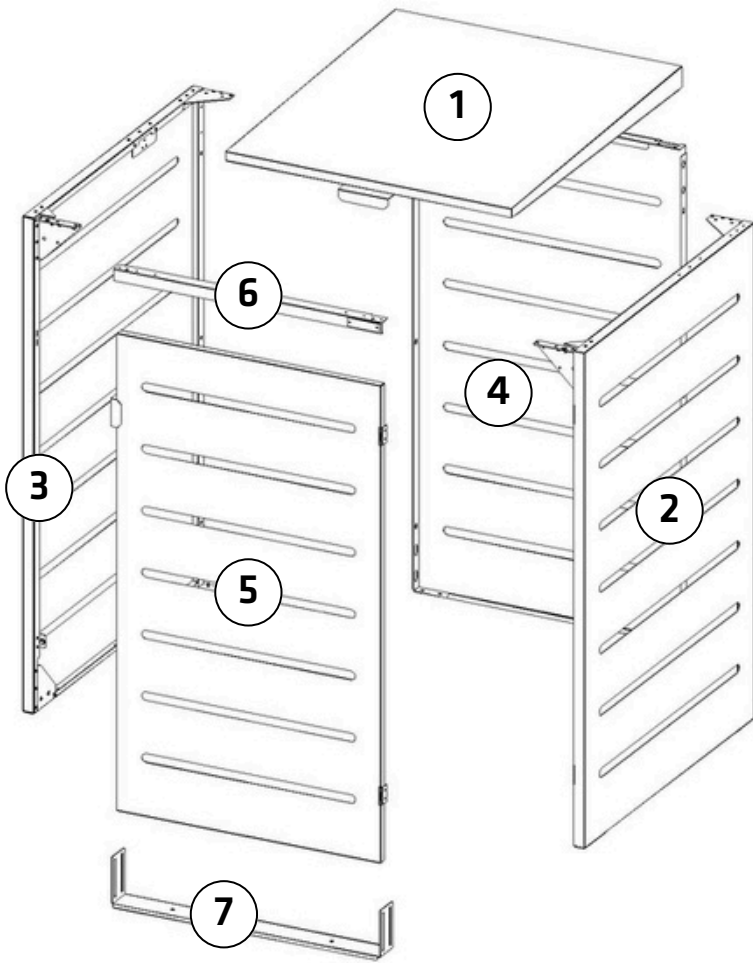

# Bestandteile des Startersets: Inhalt der Zubehör-Box

*Starter set components: content of the accessory box*

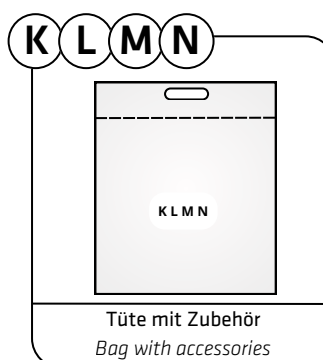
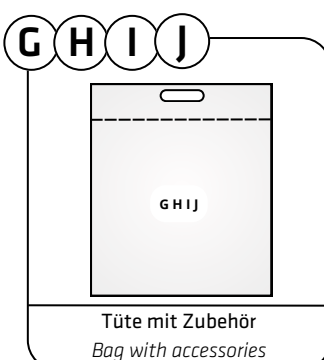
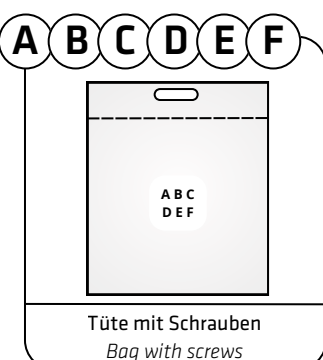
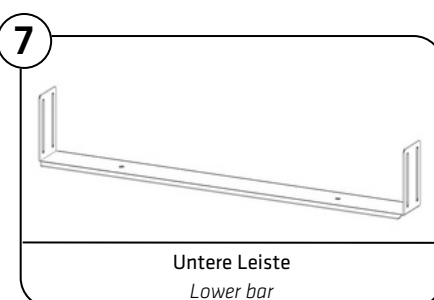
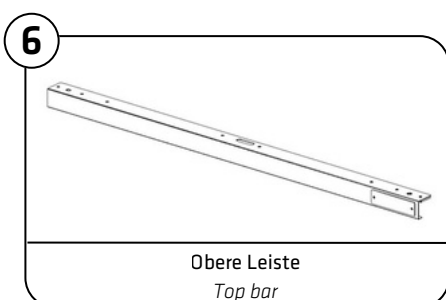
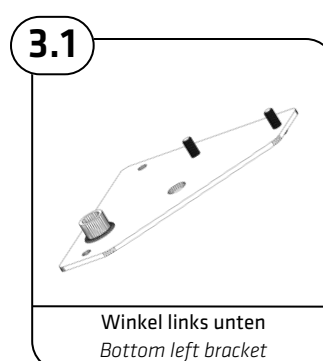
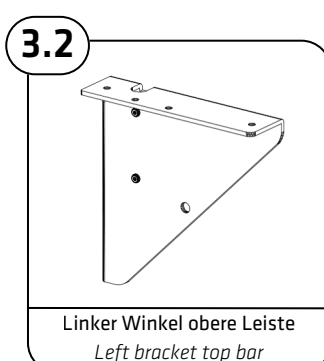
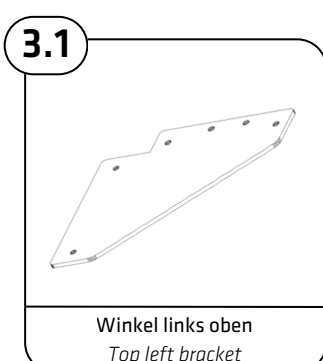
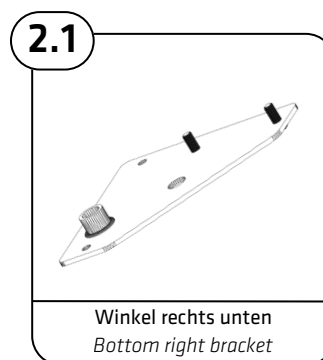
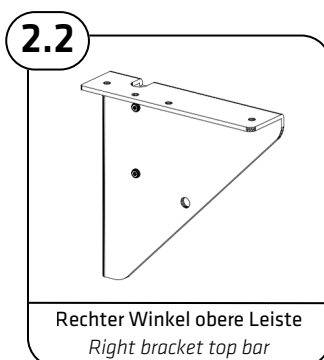
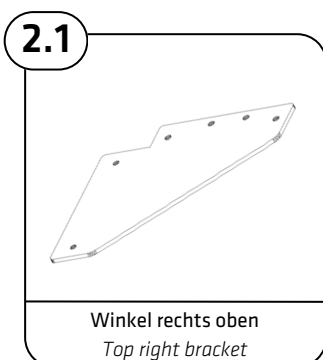
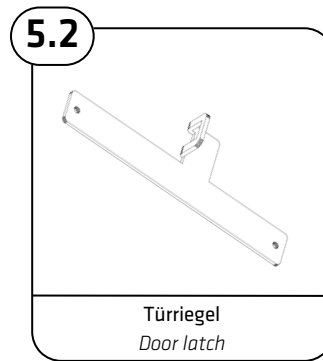
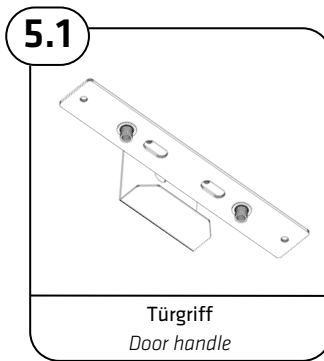
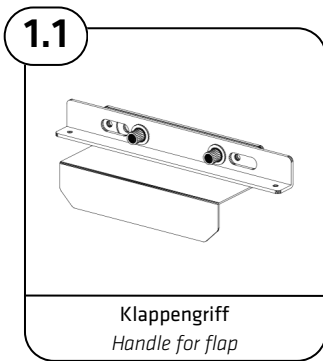

# Bestandteile des Erweiterungssets

## Extension set components

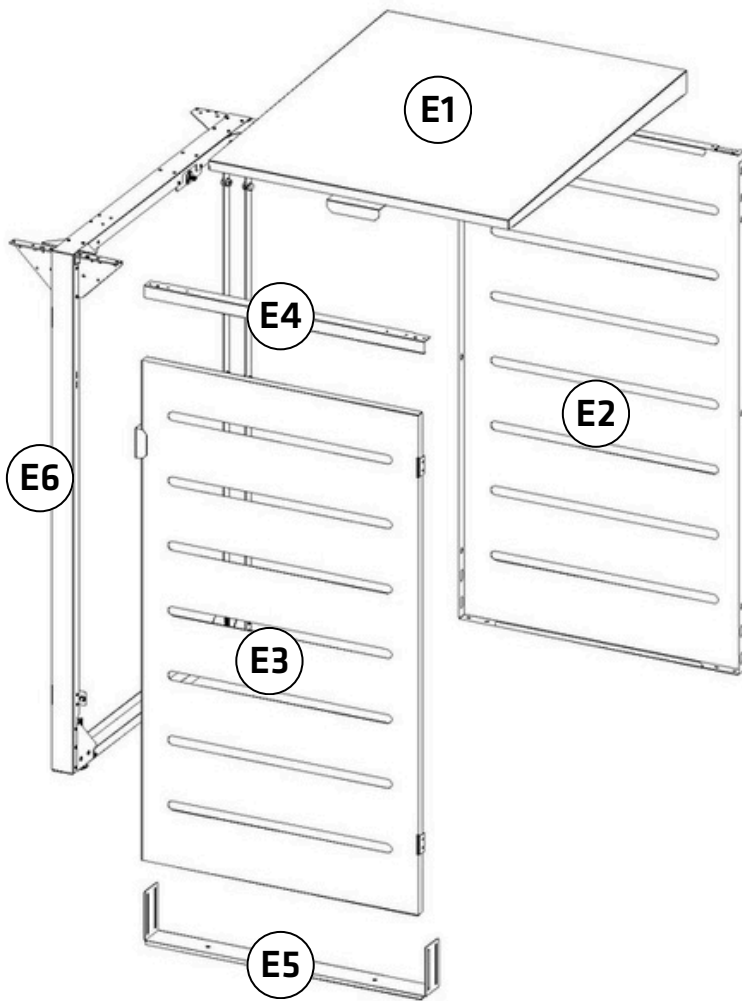

Schritte 6 bis 10 der  
Anleitung  
Steps 6 to 10 of the  
instructions

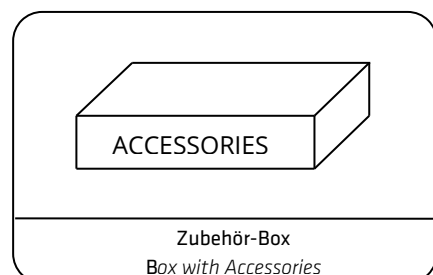
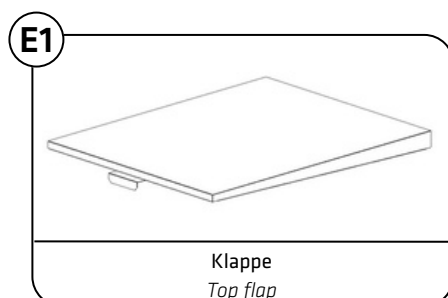
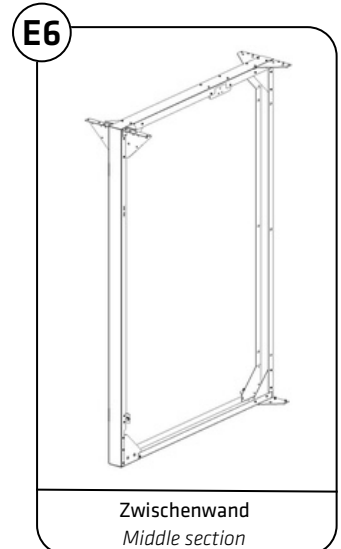
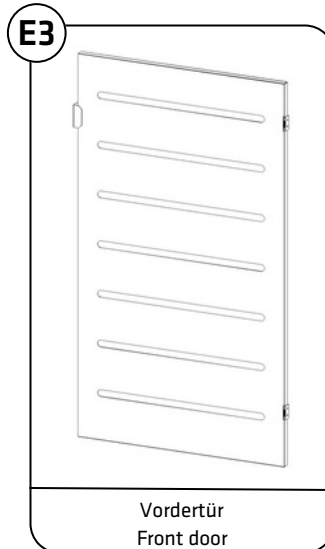
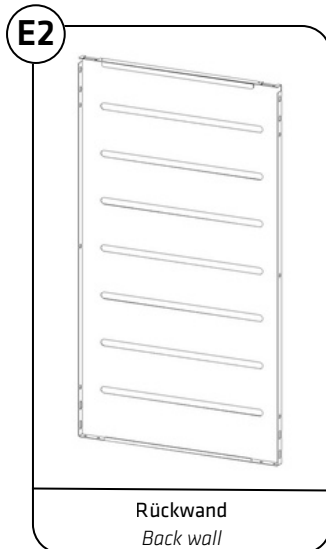

# Bestandteile des Erweiterungssets: Inhalt der Zubehör-Box

Extension set components: content of the accessory box

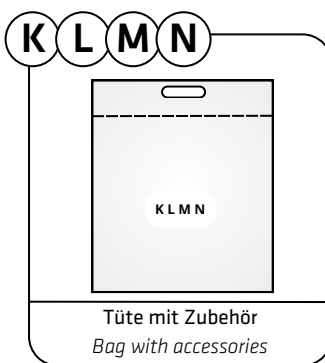
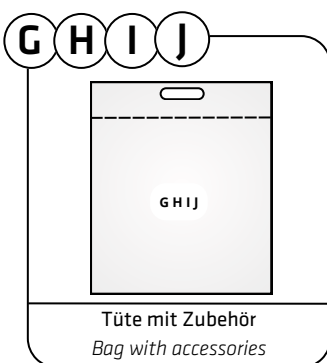
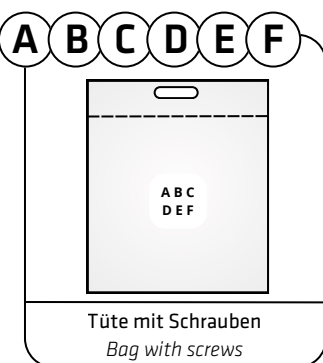
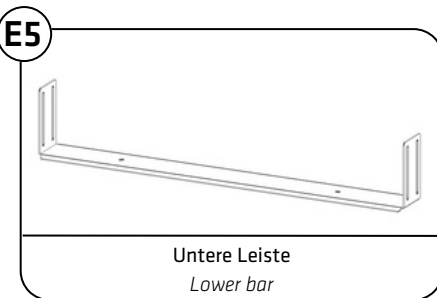
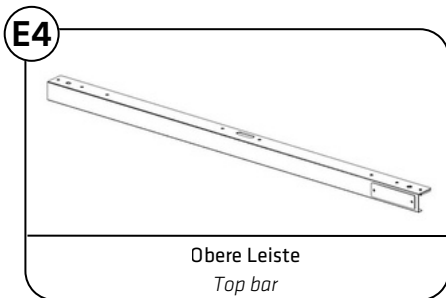
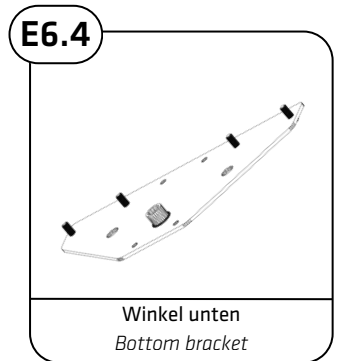
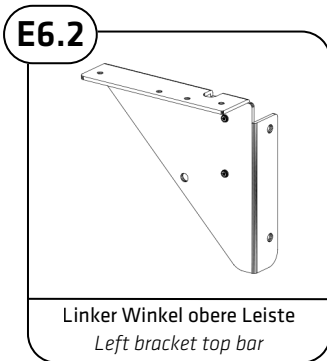
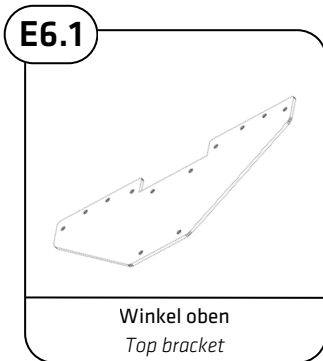
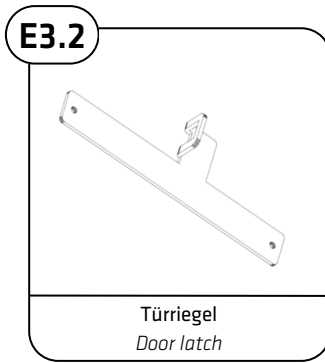
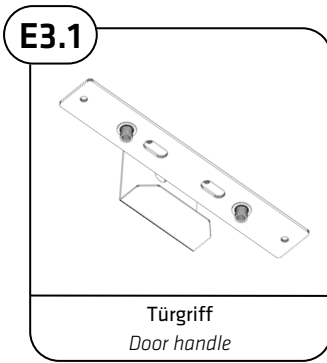
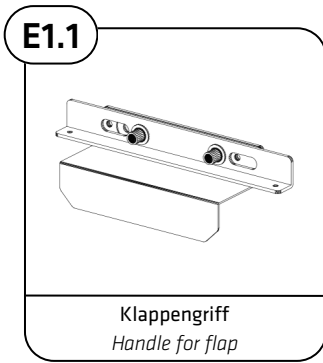

## Zubehör / Accessories



Für das Starterset und das Erweiterungsset werden die gleichen Schrauben und das gleiche Zubehör verwendet. Achten Sie darauf, dass Sie diese für eine einfachere Montage getrennt aufbewahren.

*Both the starter set and the extension set use the same set of screws and accessories. Make sure to keep them separated for easier assembly.*



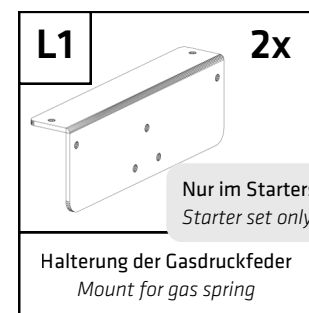
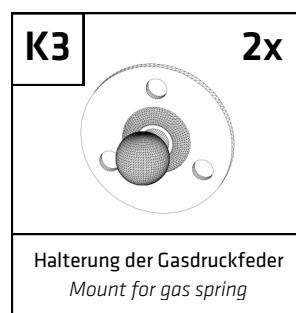
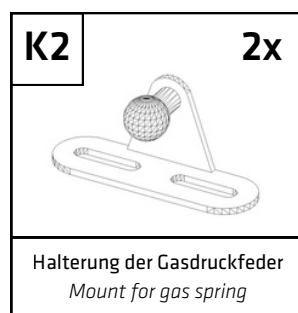
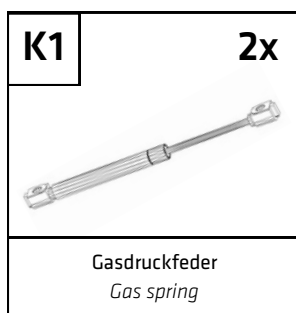
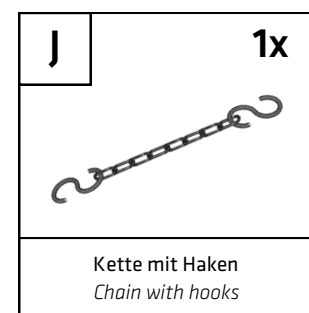
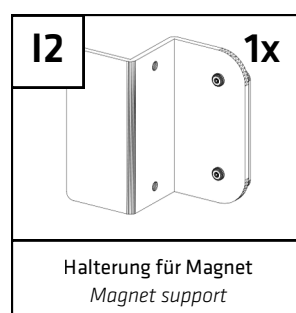
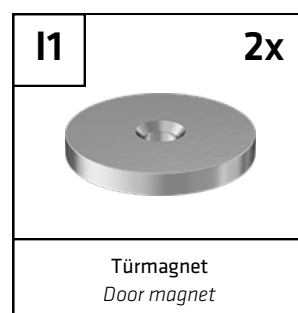
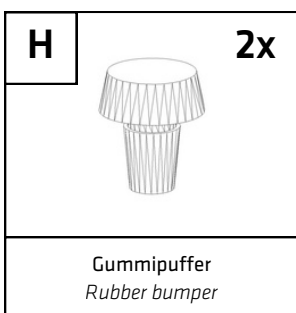
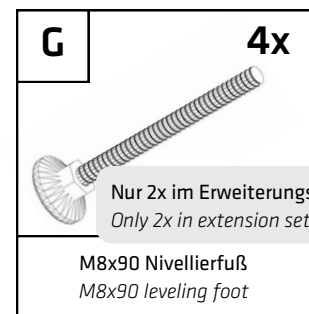
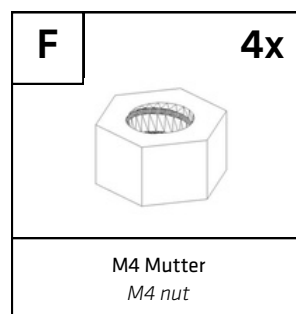
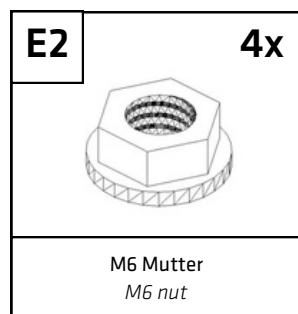
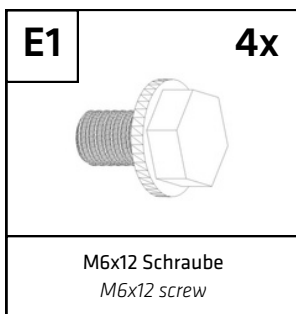
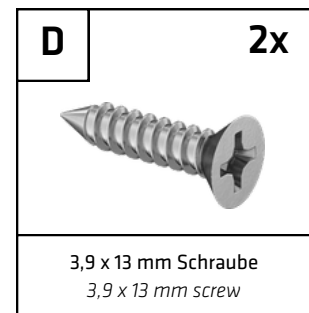
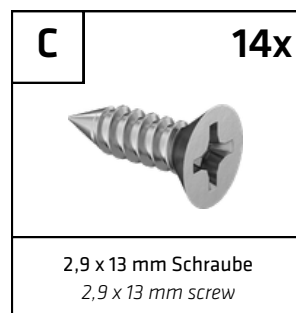
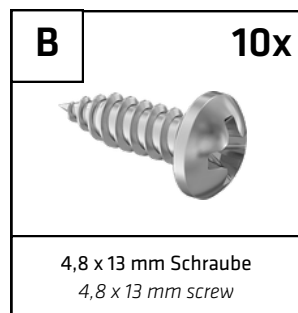
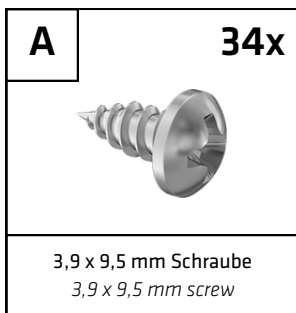

Ziehen Sie die Schrauben nur handfest an – für einen sicheren Sitz ohne Materialbeanspruchung.

*Tighten the screws only hand-tight to ensure a secure fit without stressing the material.*

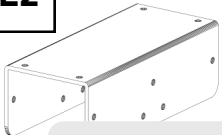

<b>L2</b>	<b>1x</b>
	
<p>Nur im Erweiterungsset. Extension set only.</p>	
<p>Halterung der Gasdruckfeder Mount for gas spring</p>	

<b>M1</b>	<b>1x</b>
	
<p>Kette für die Klappe Chain for the bin flap</p>	

<b>M2</b>	<b>2x</b>
	
<p>Karabinerhaken Clip hook</p>	

<b>M3</b>	<b>1x</b>
	
<p>Haken für Klappe Hook for bin flap</p>	

<b>N</b>	<b>2x</b>
	
<p>Klappendämpfer Flap stop</p>	

# Schritt 1: Vorbereitung der Seitenwände

## Step 1: Preparing the side walls



Bereiten Sie die rechte und linke Wand vor. Benötigte Teile:  
 Prepare the right and left wall. Necessary components:

- 2
- 2.1
- 2.2
- 2.3
- A
- B
- G
- +
- 3
- 3.1
- 3.2
- 3.3

### Schritt 1.1

#### Step 1.1

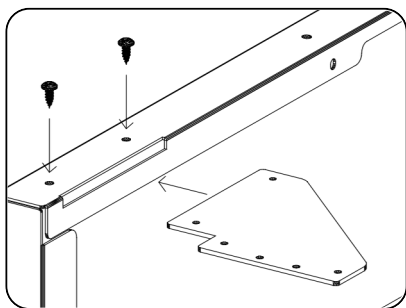

- +
- 2.1 2x A
- +
- 3.1 2x A

### Schritt 1.3

#### Step 1.3

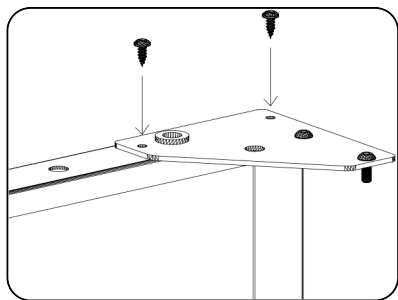

- +
- 2.3 2x A
- +
- 3.3 2x A

### Schritt 1.2

#### Step 1.2

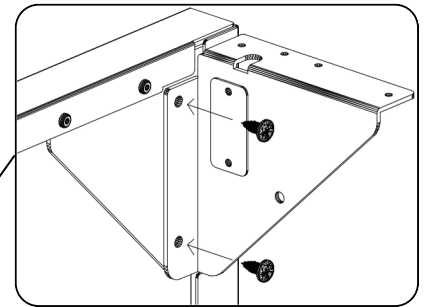

- +
- 2.2 2x B
- +
- 3.2 2x B



Drehen Sie die Wand nach Schritt 1.2 auf den Kopf. After completing step 1.2 turn the wall upside down.

### Schritt 1.4

#### Step 1.4

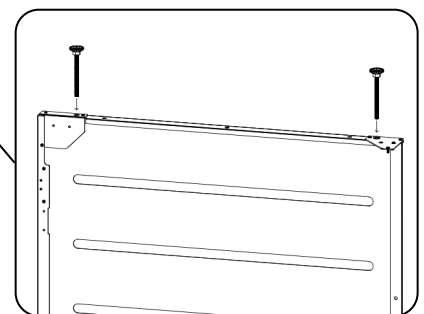

- 2x G
- 2x G

## Schritt 2: Montage der rechten Seiten- und Rückwand

### Step 2: Connecting the right and back wall



Drehen Sie die rechte Wand wieder richtig herum. Schieben Sie die Rückwand von oben nach unten in die Schlitze der rechten Wand, um sie zu verbinden. Benötigte Teile:

*Return the right wall to stand upright. Slide the back wall down into the guiding slots of the right wall to connect them. Necessary components:*



#### Schritt 2.1

##### Step 2.1

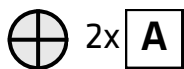
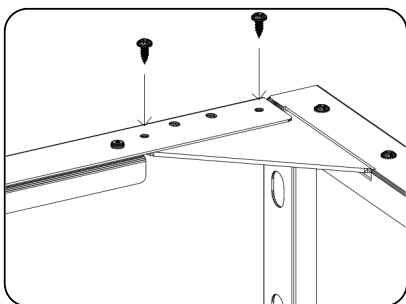

#### Schritt 2.2

##### Step 2.2

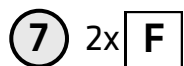
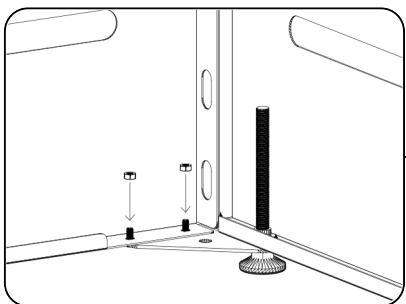

#### Schritt 2.3

##### Step 2.3

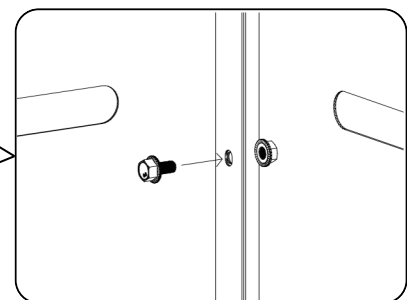

Ziehen Sie die Schrauben erst nach Abschluss der Montage fest, um eine bessere Justierung zu ermöglichen.

*Do not tighten the screws until you complete the assembly to allow better adjustment of the box later.*



Wiederholen Sie Schritt 2, um die linke Wand anzubauen, oder fahren Sie mit Schritten 3 bis 4 fort, um ein oder mehrere Erweiterungssets anzubauen. Machen Sie danach mit Schritt 5 weiter. / Repeat step 2 to add the left wall, or continue with steps 3 to 4 to add one or more extension sets. Then continue with step 5.

## Schritt 3: Vorbereitung des Erweiterungssets

### Step 3: Preparing the extension set



Bereiten Sie die Zwischenwand vor. Benötigte Teile:  
Prepare the middle section. Necessary components:

**E6** **E6.1** **E6.2** **E6.3** **E6.4** **A** **B** **G**

#### Schritt 3.1

Step 3.1

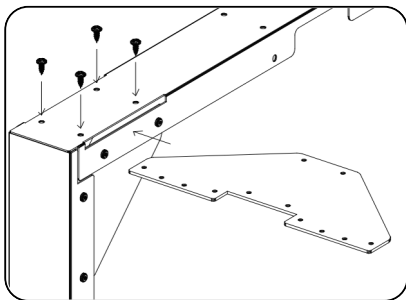

**E6.1** 4x **A**

#### Schritt 3.3

Step 3.3

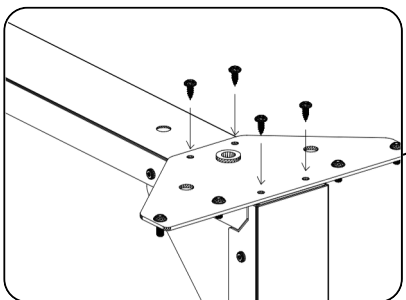

**E6.4** 4x **A**

#### Schritt 3.2

Step 3.2

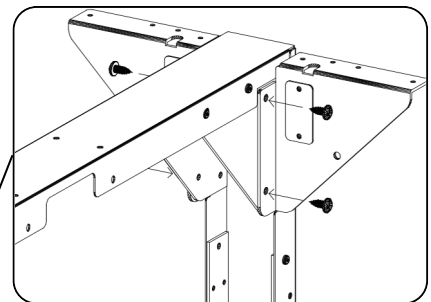

**E6.2** **E6.3**

4x **B**



Drehen Sie die Wand nach Schritt 3.2 auf den Kopf. After completing step 3.2 turn the wall upside down.

#### Schritt 3.4

Step 3.4

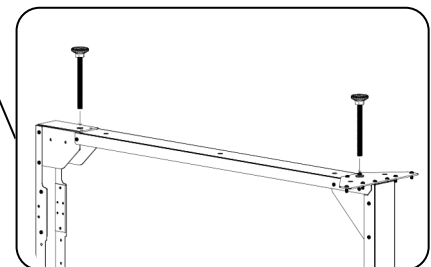

2x **G**

## Schritt 4: Anbau des Erweiterungssets

### Step 4: Connecting the extension set



Drehen Sie die Zwischenwand wieder richtig herum. Schieben Sie die Rückwand von oben nach unten in die Schlitzte der Zwischenwand, um sie zu verbinden. Benötigte Teile:

Turn the middle section to stand upright. Slide the back wall down into the guiding slots of the middle section to connect them. Necessary components:



#### Schritt 4.1

##### Step 4.1

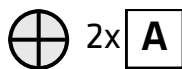
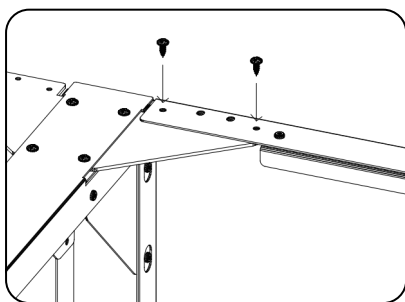

#### Schritt 4.1

##### Step 4.1

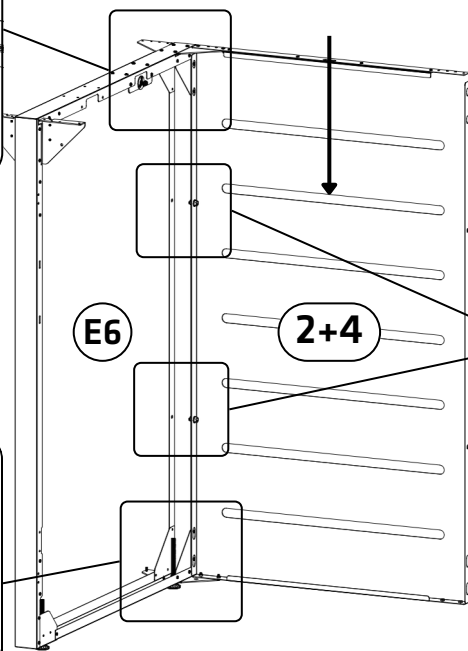
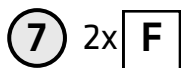
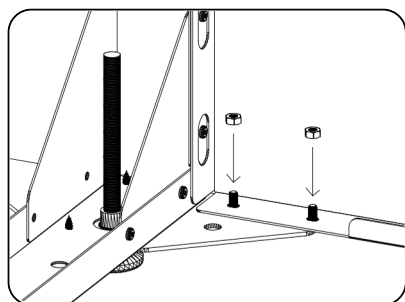

#### Schritt 4.3

##### Step 4.3

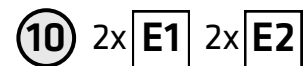
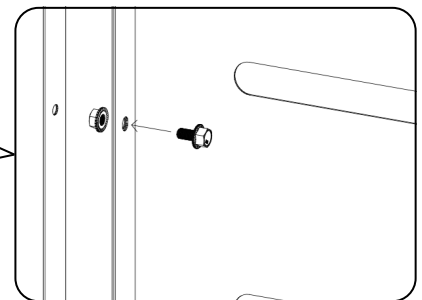

Ziehen Sie die Schrauben erst nach Abschluss der Montage fest, um eine bessere Justierung zu ermöglichen.

Do not tighten the screws until you complete the assembly to allow better adjustment of the box later.



Wiederholen Sie Schritte 3 bis 4 für alle Erweiterungssets. Kehren Sie danach zu Schritt 2 zurück, um die linke Wand anzubauen.

Repeat steps 3 to 4 for all of your extension sets. Then return to step 2 to add the left wall.

## Schritt 5: Ausrichten der Mülltonnenbox

### Step 5: Leveling the box



Richten Sie die Mülltonnenbox mit Hilfe der Wasserwaage und der Nivellierfüße aus. Vergewissern Sie sich, dass sie gerade steht, bevor Sie mit der Montage fortfahren. Dann können Sie die Schrauben aus den vorherigen Schritten festziehen.

*Adjust the level of the bin box using the level and adjustable feet. Make sure it is straight before continuing the assembly. Then you can tighten the connecting screws from the previous steps.*

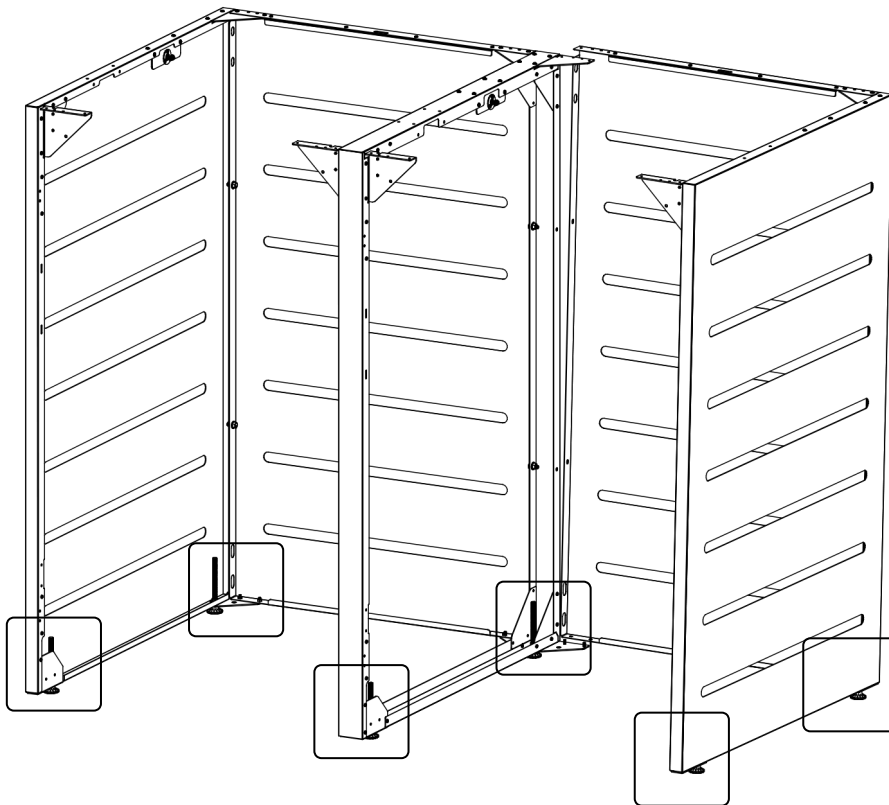

## Schritt 6: Anbringen der oberen Leiste

Step 6: Connecting the top bar



Starterset – Benötigte Teile:

Starter set – Necessary components:

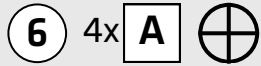

Erweiterungsset – Benötigte Teile:

Extension set – Necessary components:

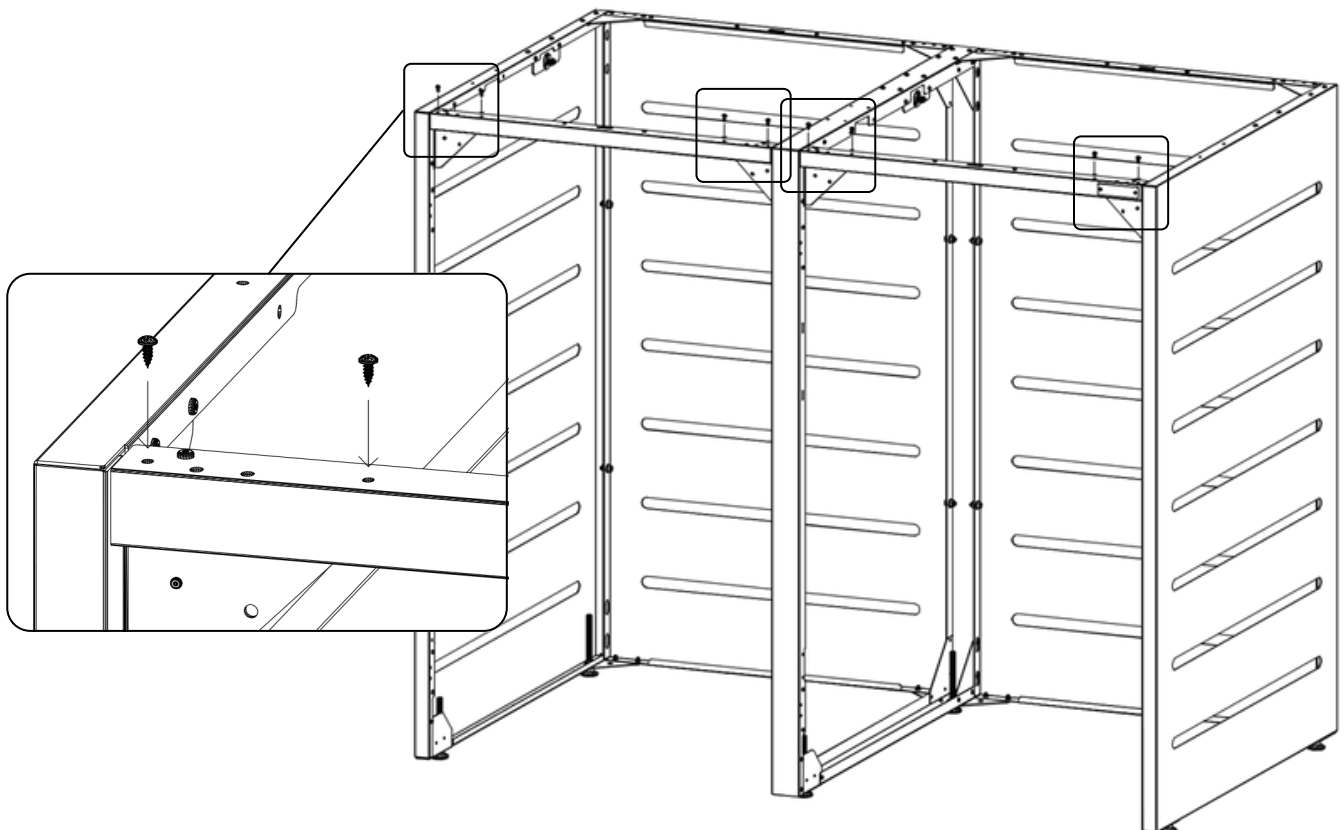
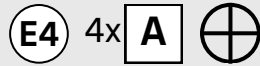

## Schritt 7: Anbringen der unteren Leiste

Step 7: Connecting the lower bar



Starterset – Benötigte Teile:

Starter set – Necessary components:

7 4x B

Erweiterungsset – Benötigte Teile:

Extension set – Necessary components:

E5 4x B



Bringen Sie die untere Leiste so an, dass sie ebenerdig ist.  
Attach the lower bar so that it is level with the ground.

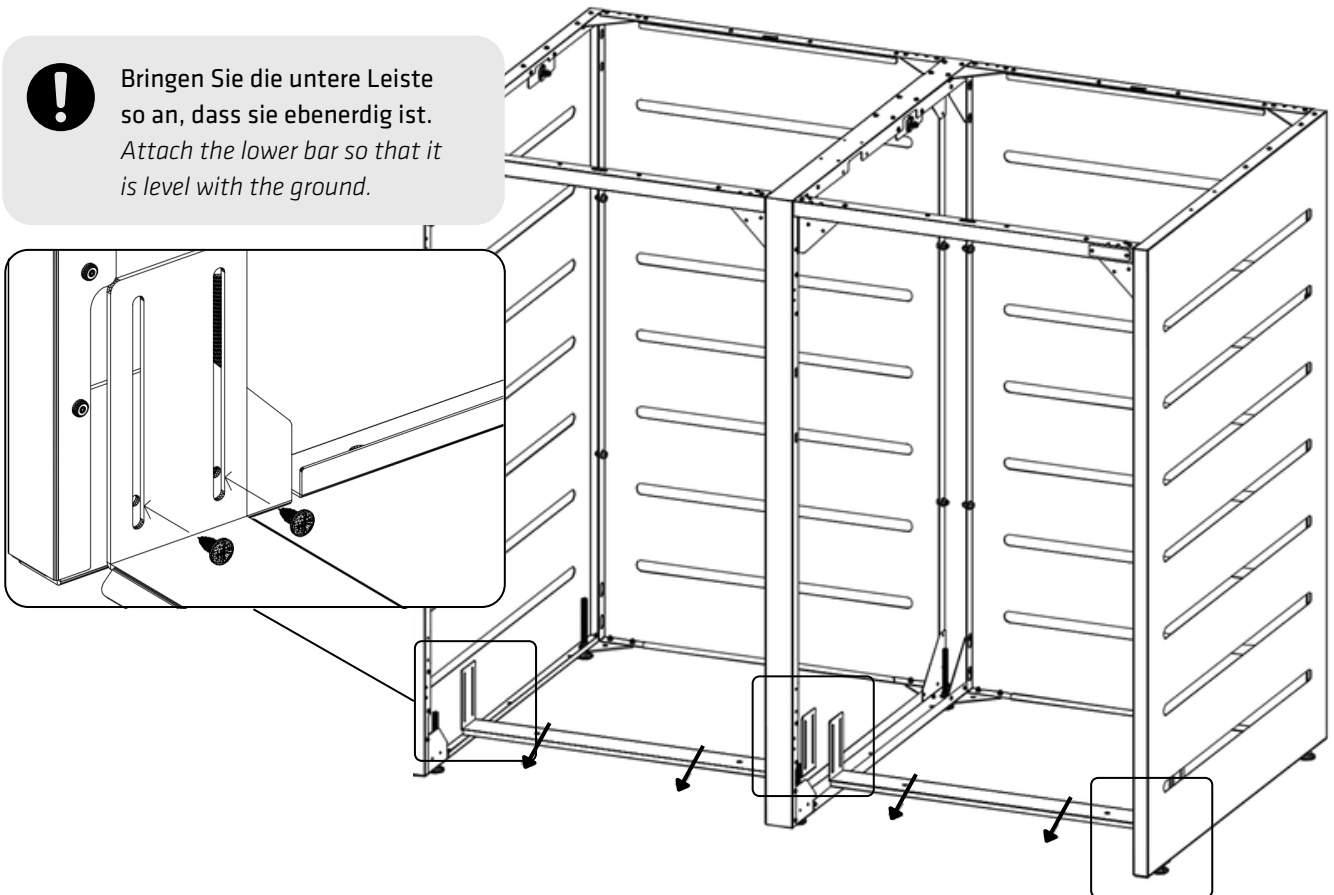

## Schritt 8: Anbringen der Tür

### Step 8: Connecting the door



Entscheiden Sie, ob Sie die Tür nach rechts oder nach links öffnend montieren möchten. Lassen Sie sich beim Anbringen der Tür von einer anderen Person helfen. Vergewissern Sie sich, dass die Tür gerade ist, bevor Sie die Schrauben festziehen.

*Decide whether you want to install the door so that it opens to the right or to the left. Ask another person to help you fit the door. Make sure that the door is straight before tightening the screws.*

Starterset - Benötigte Teile:

*Starter set - Necessary components:*



Erweiterungsset - Benötigte Teile:

*Extension set - Necessary components:*

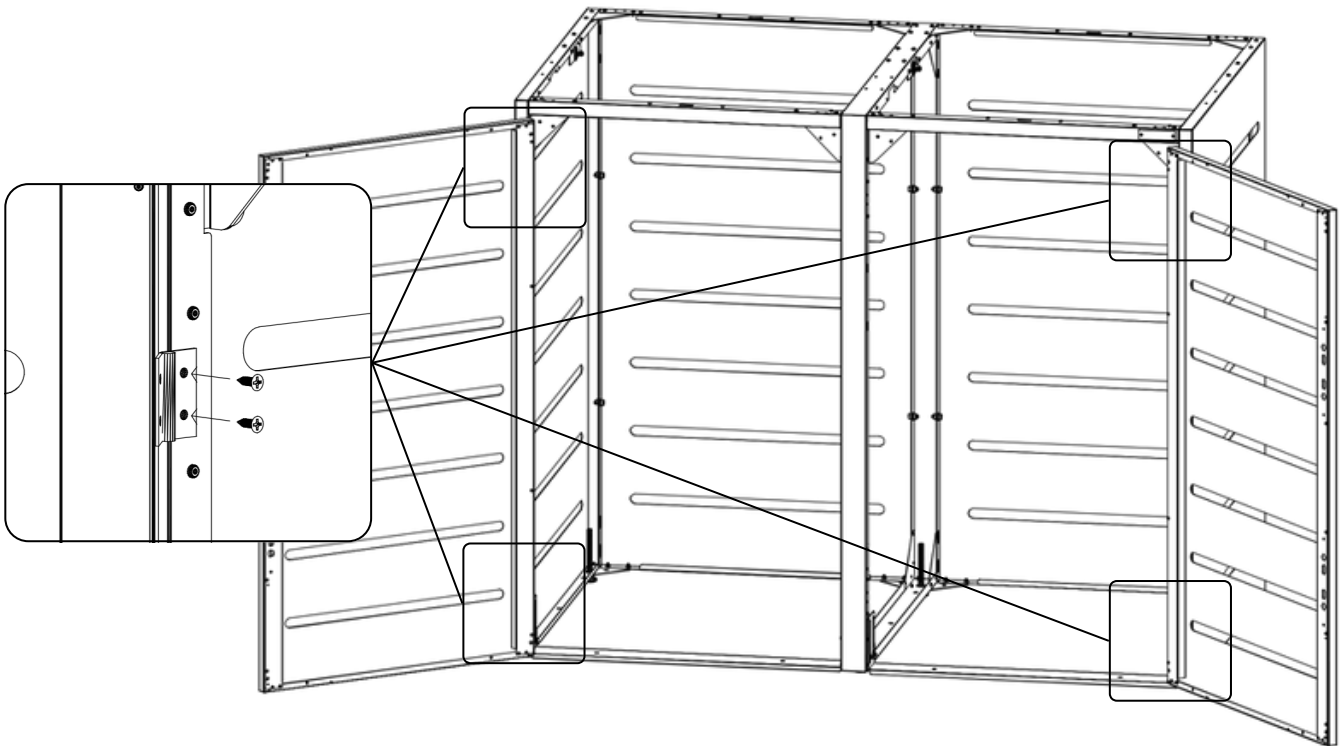

# Schritt 9: Anbringen des Griffs und der Magneten

## Step 9: Connecting the handle and magnets



Starterset – Benötigte Teile:

Starter set – Necessary components:

5 5.1 5.2 A B D I1 I2 J ⊕

Erweiterungsset – Benötigte Teile:

Extension set – Necessary components:

E3 E3.1 E3.2 A B D I1 I2 J ⊕

### Schritt 9.1

Step 9.1

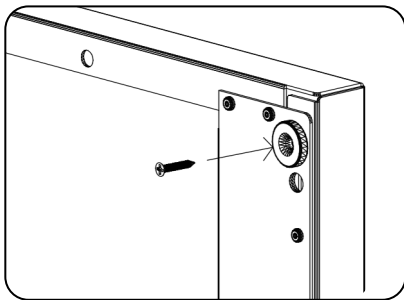

⊕ 2x I1 2x D

### Schritt 9.2

Step 9.2

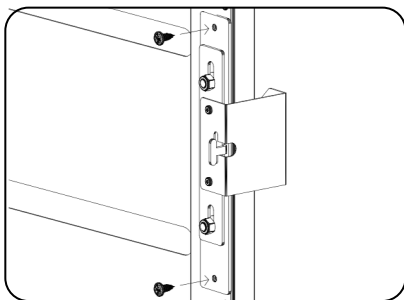

⊕ 5.1 2x B

⊕ E3.1 2x B

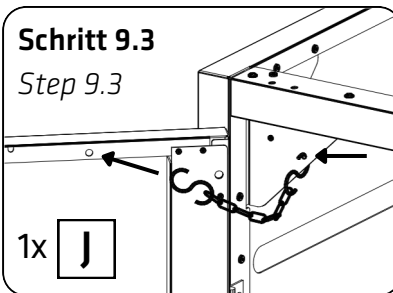

### Schritt 9.3

Step 9.3

1x J

### Schritt 9.4

Step 9.4

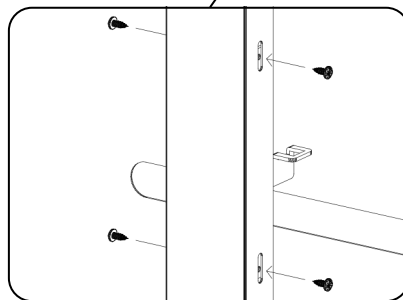

⊕ 5.2 2x A

⊕ E3.2 2x A

### Schritt 9.5

Step 9.5

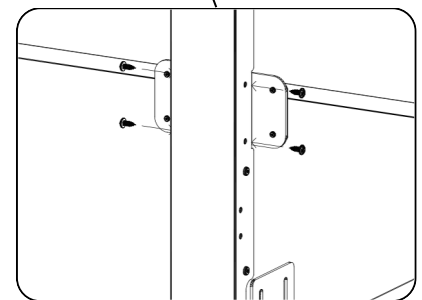

⊕ 2x I2 2x A

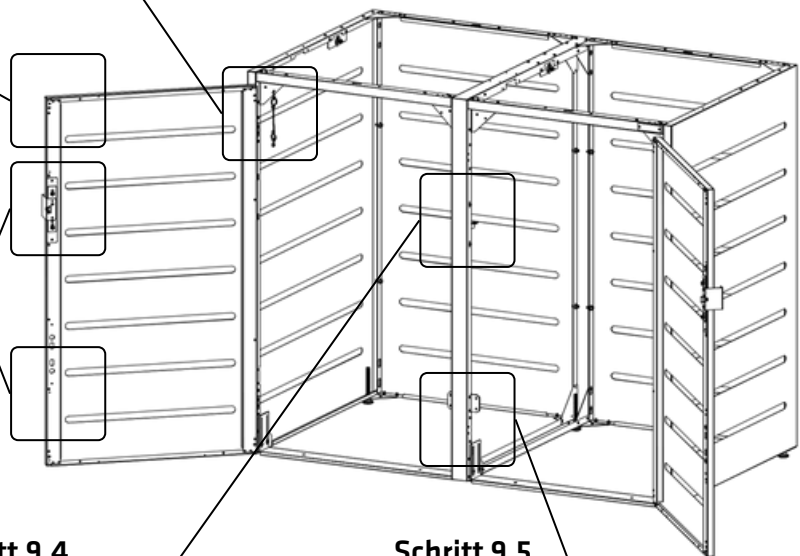

## Schritt 10: Vorbereitung der Klappe

### Step 10: Preparing the flap



Starterset – Benötigte Teile:

Starter set – Necessary components:



Erweiterungsset – Benötigte Teile:

Extension set – Necessary components:



#### Schritt 10.1

##### Step 10.1

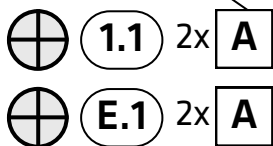
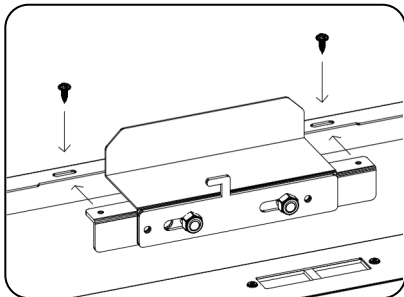

#### Schritt 10.2

##### Step 10.2

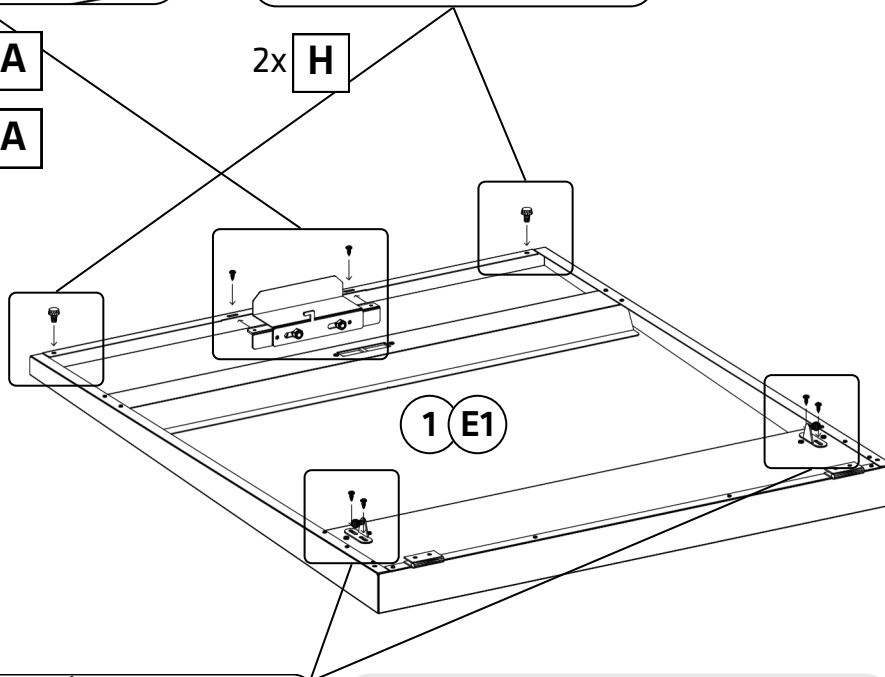
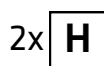
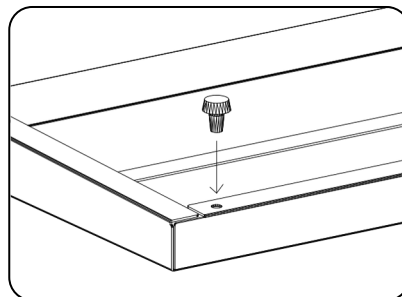

#### Schritt 10.3

##### Step 10.3

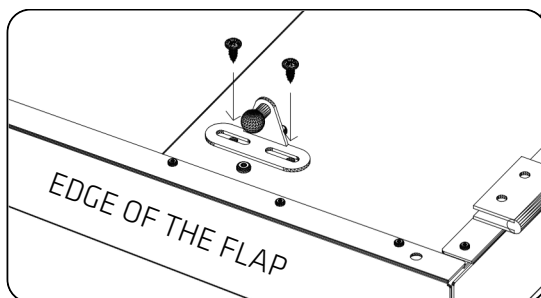

Achten Sie darauf, dass die Halterungen für die Gasdruckfeder (K2) zur Außenkante der Klappe zeigen.

Make sure that the mounts for the gas spring (K2) are facing the outer edge of the flap.

# Schritt 11: Vorbereitung der Box auf den Anbau der Klappe

## Step 11: Preparing the box for connecting the flap



Entscheiden Sie, ob Sie die Klappe nach vorne oder nach hinten öffnend montieren möchten.

*Decide whether you want to install the flap so that it opens forwards or backwards.*

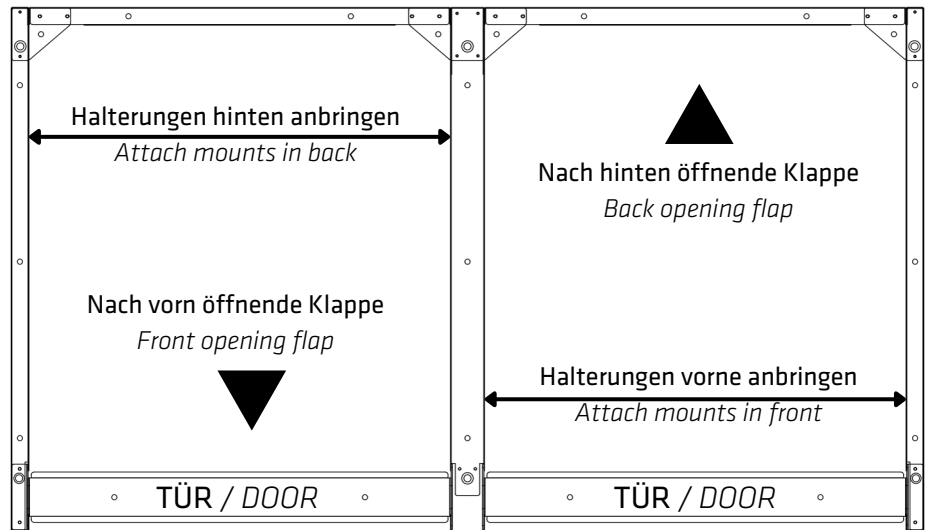

**Starterset – Benötigte Teile:**  
*Starter set – Necessary components:*



**Erweiterungsset – Benötigte Teile:**  
*Extension set – Necessary components:*



### Schritt 11.1

#### Step 11.1

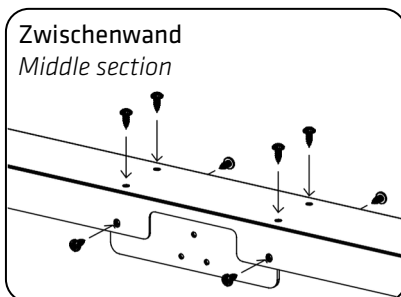
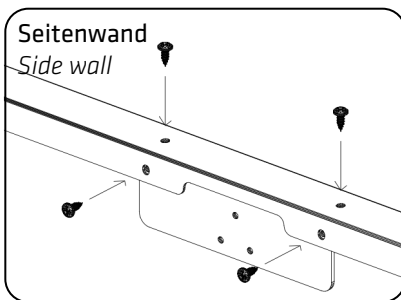

### Schritt 11.2

#### Step 11.2

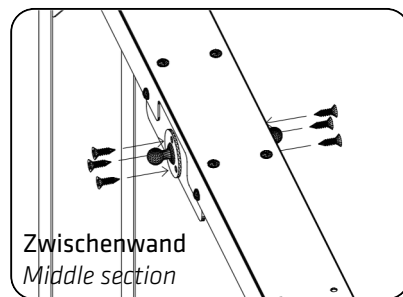
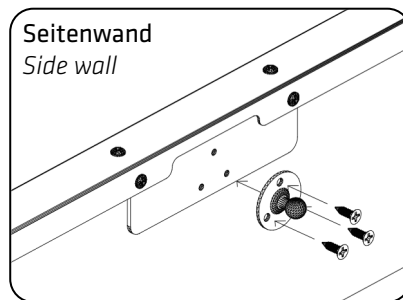

## Schritt 12: Anbringen der Klappe

### Step 12: Attaching the flap



Lassen Sie sich beim Anbringen der Klappe von einer anderen Person helfen.  
Vergewissern Sie sich, dass die Klappe gerade ist, bevor Sie die Schrauben festziehen.  
*Ask another person to hold the flap while you screw in the hinges. Make sure that the flap is straight before tightening the screws.*

Starterset – Benötigte Teile:  
*Starter set – Necessary components:*



Erweiterungsset – Benötigte Teile:  
*Extension set – Necessary components:*



#### Schritt 12.1

##### Step 12.1

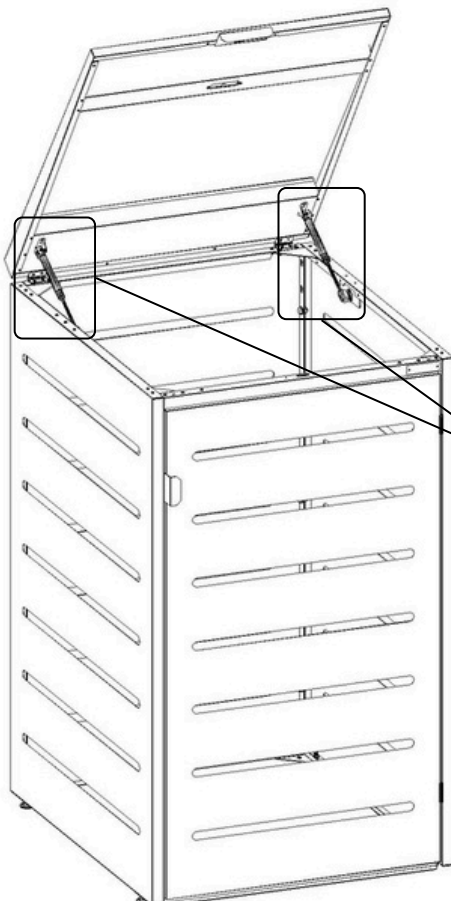
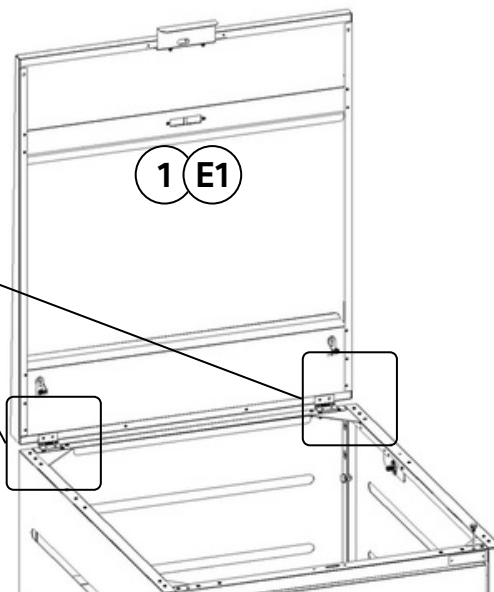
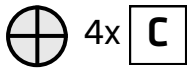
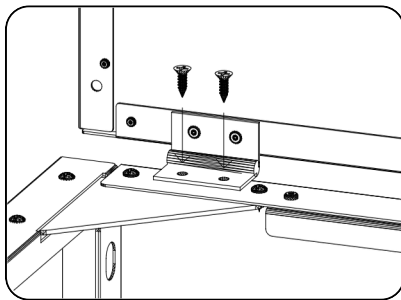

#### Schritt 12.2

##### Step 12.2

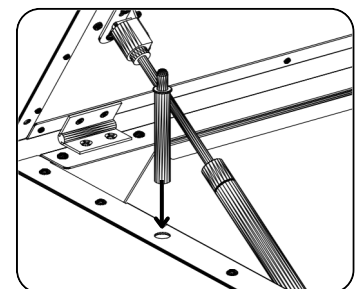
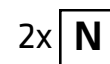
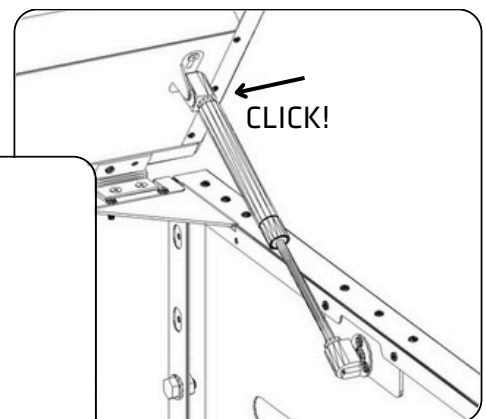
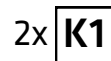
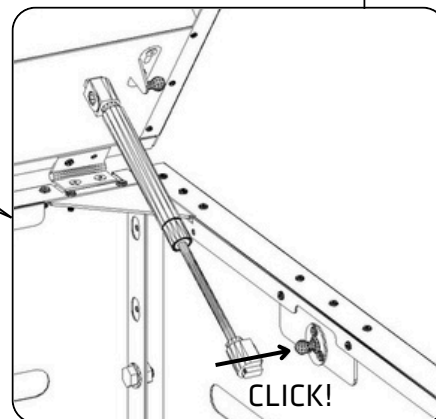

## Schritt 13: Anbringen der Kette

### Step 13: Attaching the chain



Benötigte Teile:

Necessary components:

M1

M2

M3

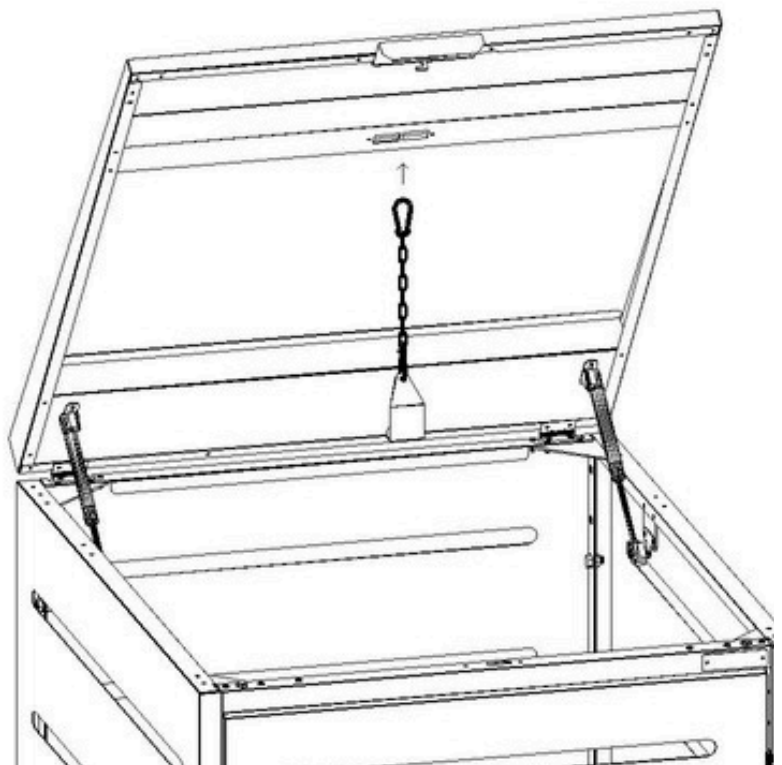
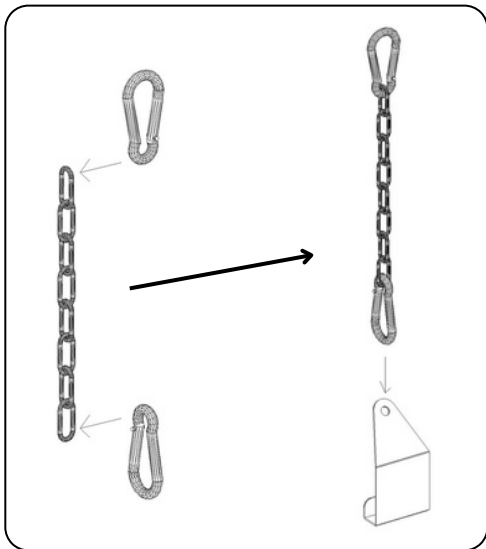

## Schritt 14: Bodenverankerung

### Step 14: Anchoring the box to the floor

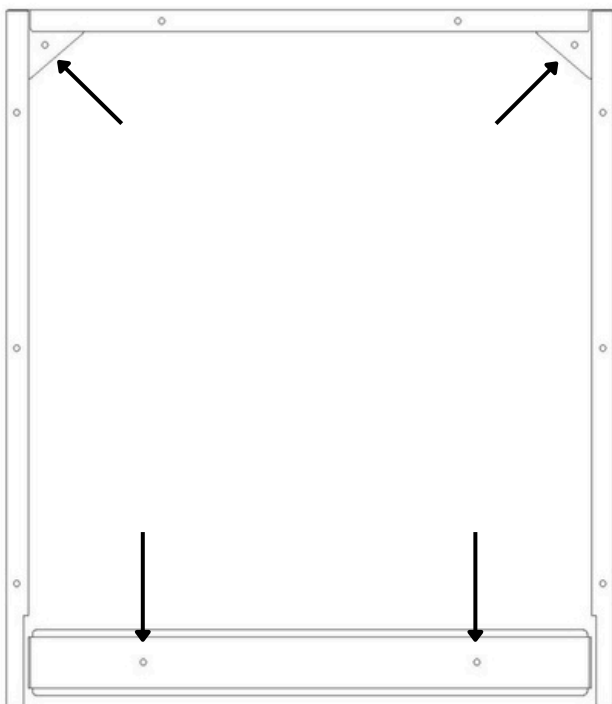

Die Mülltonnenbox muss im Boden verankert werden, um richtig gesichert zu sein! Das Montagematerial für die Bodenverankerung hängt vom Untergrund ab und ist daher nicht im Lieferumfang enthalten. Vergewissern Sie sich, dass die Box eben ist, bevor Sie sie im Boden verankern.

*The bin box needs to be anchored in the ground to be properly secured! The installation material needed depends on the surface and is therefore not included in the scope of delivery. Make sure that the box is level before anchoring it to the ground.*

## Tür und Klappe öffnen

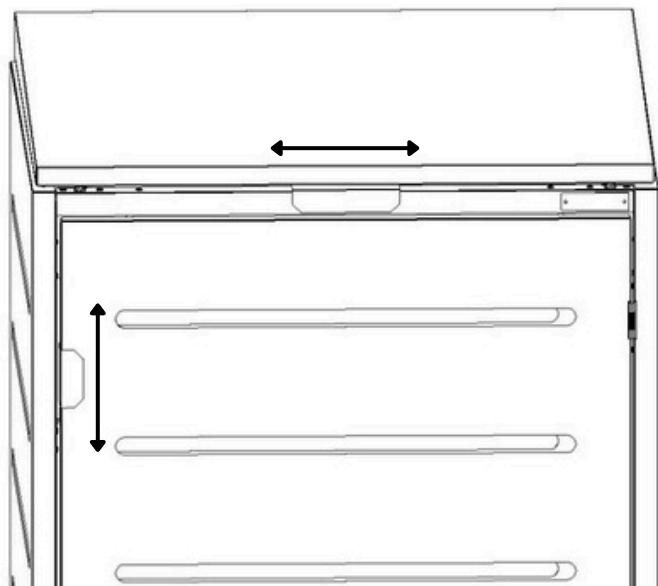

*Opening the door and flap*



Um die Tür zu öffnen, ziehen Sie den Griff nach oben. Um die Klappe zu öffnen, schieben Sie den Griff nach rechts.

*Pull the handle up to open the door. Slide the handle to the right to open the flap.*

Modell- und technische Änderungen sowie Irrtümer vorbehalten. Alle Inhalte sind urheberrechtlich geschützt.  
*Model, program and technical changes are subject to change. All contents are protected by copyright.*

Max Knobloch Nachf. GmbH, Burgstraße 38, 04720 Döbeln / Germany  
Telefon: +49 3431 6064-200 | E-Mail: [info@max-knobloch.com](mailto:info@max-knobloch.com)  
[www.max-knobloch.com](http://www.max-knobloch.com) |  [knobloch1869](https://www.facebook.com/knobloch1869) |  [knoblochbriefkasten](https://www.instagram.com/knoblochbriefkasten)